



303 MESSNER DR. • WHEELING, IL • 60090
 847-459-1460 • FAX 847-459-1569
 WWW.LUND-INDUSTRIES.COM

Installation Instructions For FP-55 Offset Transmission Hump Base

The base is normally shipped unassembled. The parts may be bolted together in a compact arrangement to prevent damage during shipment. In some cases the post assembly is shipped already attached to a mount head.

1. Assemble the base as shown in Figure 1. Place the square plate so the countersunk holes face down. Place the post assembly on the plate, so its four mounting holes are over the four holes closest to the center of the plate. Pass (4) 3/8-16 flat head screws up through the holes in the plate and post assembly, and add washers and nuts.
2. Using 3/8-16 carriage bolts with washers and nuts, mount the other two parts as shown in Figure 1, but do not tighten these nuts. (Note that the hole pattern is located in the right rear corner.)
3. Before installing the base, orient the top plate on the post as shown in Figure 1. To do this, loosen the bolt at the top of the post one turn. If necessary, tap on the top of the bolt until the upper part of the post moves freely.
4. Install the base in the vehicle with the vertical foot assembly on the floor just to the right of the hump.
5. Use machine bolt and nuts of the largest size that will fit the holes in the base. *Do not use lag screws or sheet metal screws, as these can pull out of the floor.* We recommend placing fender washers, which have a larger outside diameter than regular washers, on the back side of the mounting surface. Placing the bolts so that the nuts are inside the vehicle will prevent corrosion from freezing the nuts on the bolts.
6. To adjust the height of the post, loosen the bolt at the top of the post one turn. If necessary, tap lightly on the top of the bolt to release the top plate. Adjust the height and direction of the top plate and re-tighten the bolt.

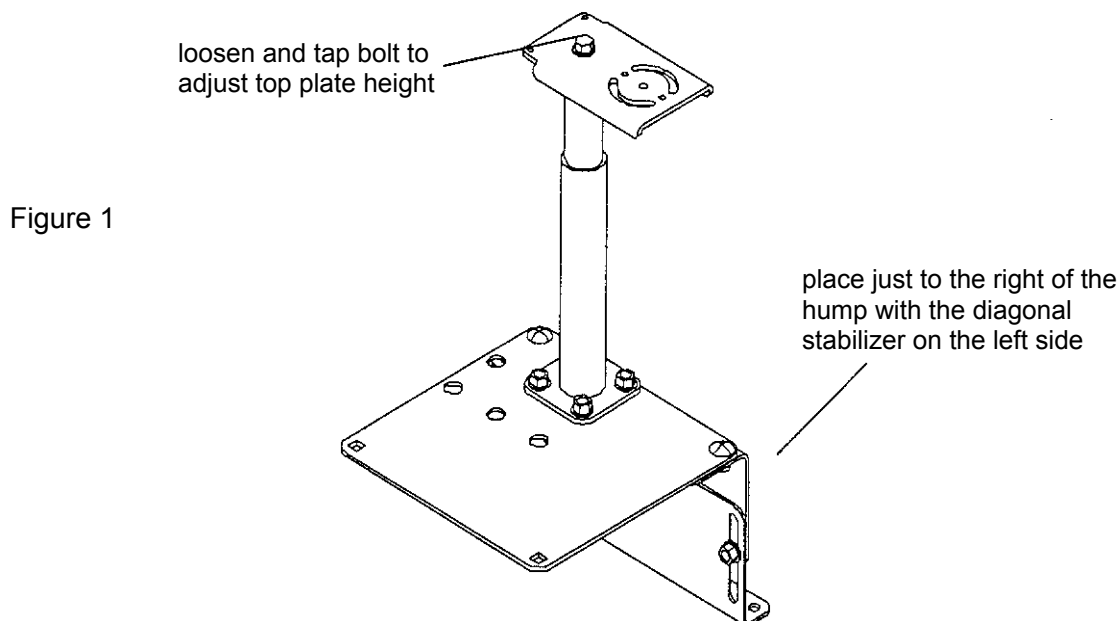

Figure 1